

**FAA Approved Installation Manual for the EDM-711 Primary
Temperature Indicating System**

**Page Page 1 of 23
Report No. 106P Rev. B
Date: 8-02-01**

TABLE OF CONTENTS

	Page
1. INSTRUMENT MARKINGS	2
2. INITIAL BENCH CHECK	2
3. LOCATION OF, AND INSTALLING THE INDICATOR	2
4. EXHAUST GAS TEMPERATURE PROBE	2
5. REMOVE THE FACTORY TIT GAGE	3
6. PRIMARY CHT PROBE INSTALLATION	3
7. SPARK PLUG GASKET CHT PROBE	3
8. OIL TEMPERATURE PROBE INSTALLATION	3
9. OUTSIDE AIR TEMPERATURE PROBE	3
10. INDUCTION AIR TEMPERATURE PROBE	3
11. RADIAL ENGINES	3
12. FUEL FLOW OPTION	4
13. WIRING	4
14. EGT AND CHT PROBE WIRING MARKINGS	4
15. MANIFOLD PRESSURE SENSOR	5
16. MANIFOLD PRESSURE CALIBRATION	5
17. RPM SENSOR INSTALLATION	6
18. ROUTING THE WIRING HARNESS	6
19. DESCRIPTION/OPERATING INSTRUCTIONS	7
20. ANNUNCIATOR, PRIMARY ENGINE TEMP LIMITS	8
21. OPERATION	9
22. COMPONENT PARTS LIST	9
23. WEIGHT AND BALANCE DATA	10
24. PILOT PROGRAMMABLE MODE	10
25. CHANGING PROGRAMMED LIMITS	11
26. TROUBLE-SHOOTING	12
FIG-1 INSTRUMENT BEZEL TEMPLATE DRAWING 700124	13
FIG-2 EGT/CHT/TIT PROBE PLACEMENT	14
FIG-3 EGT PROBE INSTALLATION	15
FIG-6 EGT/CHT PICTORIAL LAYOUT	16
FIG-7 WIRING DIAGRAM DRAWING 300701	17
FIG-8 FUEL FLOW WIRING DRAWING 700744	18
FIG-9 DRAWING 5057 WIRE PREPARATION	19
FIG-10 DRAWING 711700 REMOTE LIGHT ASS'Y.	20
FIG-11 DRAWING 700905 PLACARDS	21
Instructions for Continued Airworthiness (ICA)	22
APPENDIX A, FUEL FLOW TRANSDUCER INSTALLATION	

THE OWNER OF THE EDM-711 MUST KEEP THIS MANUAL

J.P.INSTRUMENTS

PO BOX 7033

HUNTINGTON BEACH CA 92615

1. INSTRUMENT MARKINGS

The TSO label on the side of the instrument is marked as to the primary function of the instrument. The primary temperature limit of the instrument is also marked. The part number of the instrument is as follows: Model designation system by part number for EDM-711. If the function is primary, "P" is placed in the bracket. If the function is installed but not primary and "X" is placed in the bracket.

EGT-701- [6] C -O [P] -A [X] -T [P] -I [] - F [] - [X] R/M

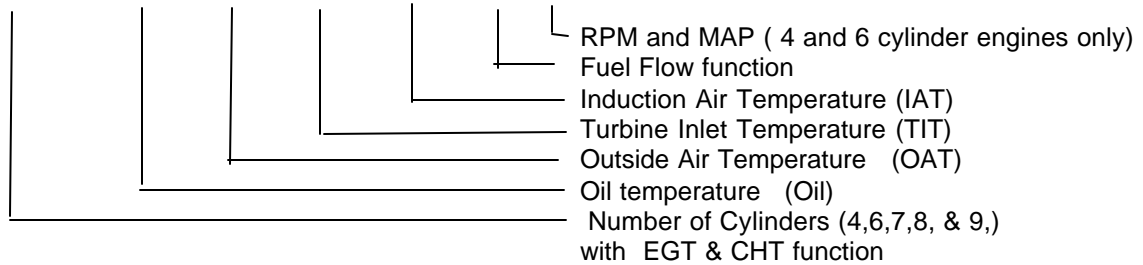

**Instrument Label found next to TSO label
 Primary Limits**

Primary Engine Temperature Limits		
CHT	OIL	TIT
460 F	230 F	1650 F

2. INITIAL BENCH CHECK

Verify that the maximum temperature label on the side of the instrument and the placard for the six remote light limits matches the Aircraft Flight Manual (AML) or Pilots Operating Manual (POH) published Limits. The airframe manufacturer may have additional limitations on the operation of your engine as well as any current AD's and STC's. Do Not attempt to remove or replace the limit stickers. The Over-Temp light has been calibrated to come on at the temperature limits displayed on the front and side of the gauge. If the temperature limits do not match that which are specified for your aircraft send this unit back to JPI for re-calibration. Do not install or use a primary instrument that is not properly calibrated for your aircraft.

3. LOCATION of, and INSTALLING, the INDICATOR

The EDM-711 indicator should be located as close as possible to the pilot with an unobstructed view and for easy access to the STEP and LF buttons on the instrument. It MUST be located no farther than 20 inches horizontally and 15 inches vertically from the pilots eyes. The caution and Limit alarm lights and their placard MUST be installed directly in front fo the pilot within the pilot's primary field of view. Installation should be done In accordance With Advisory Circular AC43.13-1A

A steel template supplied with the installation kit is used as a guide for drilling two button holes in the instrument panel. Align and Mount the Template into the instrument panel hole. First drilling a 0.125 hole. Remove the template and check the instrument alignment, if OK **re-drill with a 0.147 drill**. The plastic buttons **are removable** by pulling off and pressing on.. The EDM-711 mounts in a standard 2.25" instrument hole. The instrument **configures itself automatically** for 4 or 6 cylinder engines, 14/28 volt aircraft. Mount the indicator per Figure 1(drawing 700124). Three connectors are protruding from the rear of the instrument with two connectors on a pigtail. The pigtails are 9 pin and 15 pin. The 9 pin pigtail is connected to the remote limit lights and the 15 pin pigtail is connected to the fuel flow cable. Record the installation of the EDM-711 on a FAA form 337. Make an entry in the aircraft log book.

TO PREVENT DISPLAY DAMAGE IT IS ESSENTIAL THAT THE FOUR MOUNTING SCREWS NOT PENETRATE THE INSTRUMENT MORE THAN .12 INCHES. DAMAGE OF THIS NATURE IS NOT COVERED UNDER WARRANTY.

4. EXHAUST GAS TEMPERATURE PROBE (EGT)

Remove the existing EGT gage and Probe. Replace with JPI probe M-111 in all exhaust stacks. The Model M-111 Probe will fit any existing holes in the exhaust stack in any engine having the diameter of 1/8" to 1/4". If no hole exists, it will require the drilling of a 1/8" diameter hole and ream to fit. It is important that each probe be mounted

a **uniform** distance from the exhaust stack flange. A nominal distance of 2 to 4 inches from the exhaust flange is recommended. (See fig-2). **If the recommended distance is impractical** because of obstructions, slip joints or bends in the exhaust system then position the probes a uniform distance from the flange as space permits. **Do not mount probes in slip joints.** Be certain to locate all holes BEFORE drilling to ensure that nothing interferes with the probe, clamp, screw or wire. Careful matching of probe position will provide best temperature readings.

Insert the probe in the exhaust or previously drilled hole (see fig-3) so that the tip of the probe is in the **center of the exhaust stream.** Tighten the stainless steel clamp to a torque of 45 in/Lbs. Cut off the excess strap close to the screw.

5. REMOVE THE FACTORY TURBINE INLET TEMPERATURE GAGE.

The factory installed TIT probe (K-Calibration) is compatible with the JPI EDM-711 System. Therefore remove the TIT indicator but leave the TIT probe installed. Connect the JPI wire marked TIT directly to the probe noting color polarity. The TIT probe should now have only the JPI leads attached to it, no further adjustment of the probe is required. Replacement probes should be purchased per part number from the aircraft manufacturer. TIT will appear as the seventh column with a "T" above it and the expression such as "1650 TIT" will be seen when the dot is in place over the TIT column.

TIT for second Turbine Inlet Temperature

The standard JPI TIT probe P/N M-111-T with a special clamp is placed in the exhaust stack accumulator to a **maximum** depth of 1/2 inch and approximately four (4) inches from the Turbine inlet if possible, on the wastgate side of the turbine.

6. PRIMARY CYLINDER HEAD TEMPERATURE (CHT) PROBE, INSTALLATION

For primary Indicator replacement, replace your existing CHT Probe and adapter, a bayonet or screw in type with one supplied by JPI. Install the probe on the same cylinder from which you removed the original equipment probe. The JPI probe is a bayonet probe P/N 5050-T is a K calibration and has a captive 3/8-24 boss that is screwed into the base of the cylinder. Your current CHT probe is installed in the hottest cylinder as determined by the airframe manufacturer.

7. SPARK PLUG GASKET CHT PROBE

Some engines do not have a bayonet CHT cavity in the cylinder head. The only method of measuring CHT on this type of engine is to use a thermocouple sparkplug gasket probe. The sparkplug gasket probe, P/N M-113, replaces the standard copper spark plug gasket on one spark plug. The plug chosen, upper or lower, should be the one that receives the first new air flow. After many removals, the probe should be replaced because of copper worked hardening.

8. OIL TEMPERATURE (OIL) PROBE INSTALLATION

Remove the original oil temperature gauge and sensor. The sensor port is a standard 5/8-18 thread for both the Continental and Lycoming engines. The JPI oil probe P/N 400500 is placed into the adapter P/N 400503. This assembly is identical to the factory sensor. Connect the wire marked oil temperature observing polarity. Wire length has no effect on the readings. Oil temperature will be displayed as an independent temperature like "230 OIL" and will also be displayed in the seventh column automatically if TIT is not installed. If TIT is installed it will be shown as the missing bar in the "T" bar graph. Check for oil leaks before first flight.

9. OUTSIDE AIR TEMPERATURE PROBE, OAT

Install the OAT probe, P/N 400510 in the airframe manufacturer's recommended location. If this is not possible, it is recommended that the OAT probe be placed in clean airflow such as in a cabin air scoop or below the underside of the wing away from engine heat or exhaust. In this case it is recommended that the installation be done similar to the antenna installation instructions of AC 43.12-2a "Acceptable Methods, Techniques and Practices". The outside aluminum tube is used to both hold the probe in place and shield it from radiated heat. OAT option is displayed as an independent digital temperature like "75 OAT". All wiring must be type K thermocouple wire.

10. INDUCTION AIR TEMPERATURE PROBE (IAT) / CARB TEMP.

Induction Air temperature probe, IAT, is installed just after the inter-cooler (OUT) and the Compressor Discharge Temp (CDT) just before the inter-cooler (IN). The probe is an EGT probe and installed the same way as an EGT probe. A large clamp is supplied to fit around the air port leaving the inter-cooler or a 1/8 NPT is available. IAT option is displayed as an independent digital temperature like "125 IAT". On non-turbo engines the IAT in reality is the Carburetor temperature and displayed as "34 CRB".

11. RADIAL ENGINES

Radial engine exhausts require a larger EGT clamp (supplied) to fit the 2.5 inch exhaust pipe. The EGT probe is installed in the same fashion as a Lycoming or Continental engine and should be placed between the exhaust pipe flange and the accumulator at a distance of 2 to 3 inches from the engine exhaust flange. Cylinder head temperatures are measured with a spark plug gasket type probe placed under the front sparkplugs. Front spark plugs will read 15 to 20 degrees cooler than the rear plugs. Do not route the EGT/CHT harness in with the ignition harness. Do not extend the yellow thermocouple leads with copper wire.

12. FUEL FLOW OPTION

The EDM-711 receives signal from any installed Flowscan Transducer of the following Flowscan P/N's embossed on to the top of the transducer. The K-Factor is engraved on the side of the Transducer. Wire per drawing 700744, Route the JPI wires along the existing wiring bundle lacing every foot.

Flowscan Instruments, Seattle WA 98106

FlowScan PN	Shadin equivalent PN
201-A	
201-B	680501/680600
201-C	
231	680503

Install the function switch in the panel per drawing 700744.

If no previous fuel flow transducer is installed, install transducer per Report No. 503, Appendix A (STC SA00432SE).

13. WIRING (12 / 24 volt)

The EDM-711 automatically accommodates both 14 and 28 volt electrical systems. Using the 25 pin connector, connect the power lead (red) to a **separate 2 amp circuit breaker** connected to the Master power bus. The EDM-711 has a 10-second warm-up. No connection to the aircraft dimmer system is required because the instrument dims automatically with reductions in ambient light. The Limit Lights have an independent dimmer switch which is a two position switch day/night.

14. EGT and CHT Probe Wiring Markings

The EDM-711 is supplied with special Teflon insulated Chromel Alumel factory assembled wiring harness configured for the correct number of cylinders. The wire harness is marked E-1= EGT-1, C-1= CHT-1, etc. TIT is marked "T", Oil Temp = "O" and OAT = "A".

NOTE: Unlike most other EGT & CHT installations **the probe wire length is not critical** and should be trimmed to any length as required for a clean installation. **Do not extend the thermocouple wire with copper wire.**

The Temperature probes must be wired with the correct polarity. Each wire is marked with the cylinder number. The EGT and CHT probes connect to the temperature indicator with yellow jacket Teflon Chromel Alumel wire supplied. Strip the wires according to drawing 5057 and terminate with the crimp-on ring terminals provided. Verify the quality of each crimp with a sharp pull on the wire. The terminal should be almost impossible to pull off when crimped correctly. With in a few inches of the instrument terminal strip a connector may be installed.

NOTE: The ring terminals may be crimped with a " service type " tool, however AMP part number 48518 tool is recommended. Be sure to test each crimp by pulling on the wire to assure it will not come out.

The most common installation problems are poor quality terminations.

15. Manifold Pressure (MP) Sensor

Install a T-fitting (not supplied) in the aircraft's MP gage line in the cockpit near the MP gage. Install the JPI MAP sensor P/N 604010 on the T-fitting. Connect the JPI MP sensor to the wiring harness using the 4-pin connector supplied. The MAP sensor uses a 1/8 NPT fitting. Note: this is eligible for installation on all 4 & 6 cylinder engines only. There are no alarm limits.

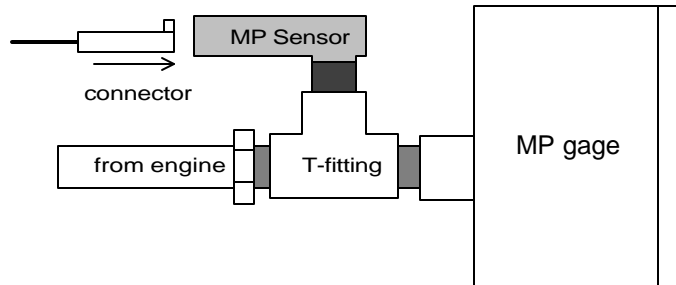

16. Manifold Pressure Calibration

The manifold pressure must be calibrated to the ambient air pressure. Enter the current ambient barometric pressure. The engine must *not* be running. This setting is *not* the same as the altimeter setting that you receive from ATIS or Unicom. It will vary with field elevation. Use the chart below to calculate the MP FACTOR. Multiply this MP FACTOR by the altimeter setting that you receive from ATIS or Unicom. For example if the field elevation is 1700 ft and the altimeter setting is 30.1, the MP FACTOR is 0.9400 from the table. Multiply 30.1 x 0.9400 to get the ambient MP of 28.29.

Field Elev.	MP FACTOR	1800	0.9366	4300	0.8540
-500	1.0182	1900	0.9332	4400	0.8508
-400	1.0145	2000	0.9298	4500	0.8477
-300	1.0109	2100	0.9264	4600	0.8445
-200	1.0073	2200	0.9230	4700	0.8414
-100	1.0036	2300	0.9196	4800	0.8382
0	1.0000	2400	0.9162	4900	0.8351
100	0.9964	2500	0.9129	5000	0.8320
200	0.9928	2600	0.9095	5100	0.8289
300	0.9892	2700	0.9062	5200	0.8258
400	0.9856	2800	0.9028	5300	0.8227
500	0.9821	2900	0.8995	5400	0.8196
600	0.9785	3000	0.8962	5500	0.8165
700	0.9750	3100	0.8929	5600	0.8135
800	0.9714	3200	0.8896	5700	0.8104
900	0.9679	3300	0.8863	5800	0.8074
1000	0.9644	3400	0.8830	5900	0.8043
1100	0.9609	3500	0.8798	6000	0.8013
1200	0.9574	3600	0.8765	6100	0.7983
1300	0.9539	3700	0.8733	6200	0.7953
1400	0.9504	3800	0.8700	6300	0.7923
1500	0.9469	3900	0.8668	6400	0.7893
1600	0.9435	4000	0.8636	6500	0.7863
1700	0.9400	4100	0.8604	6600	0.7833
		4200	0.8572	6700	0.7804

17. RPM Sensor installation

There are four types of magnetos commonly in use. You must have the correct RPM sensor for the magneto installed in the aircraft. The following part numbers apply: Slick -4000, -6000 series use JPI P/N 420809. For the Bendix -1200 series use P/N 420807. Dual magnetos use JPI PN 420815. For the Bendix -20 series use JPI P/N 420806. Mount the sensor as shown in the appropriate diagram below. Note: this is eligible for installation on all 4 & 6 cylinder engines only. There are no alarm limits.

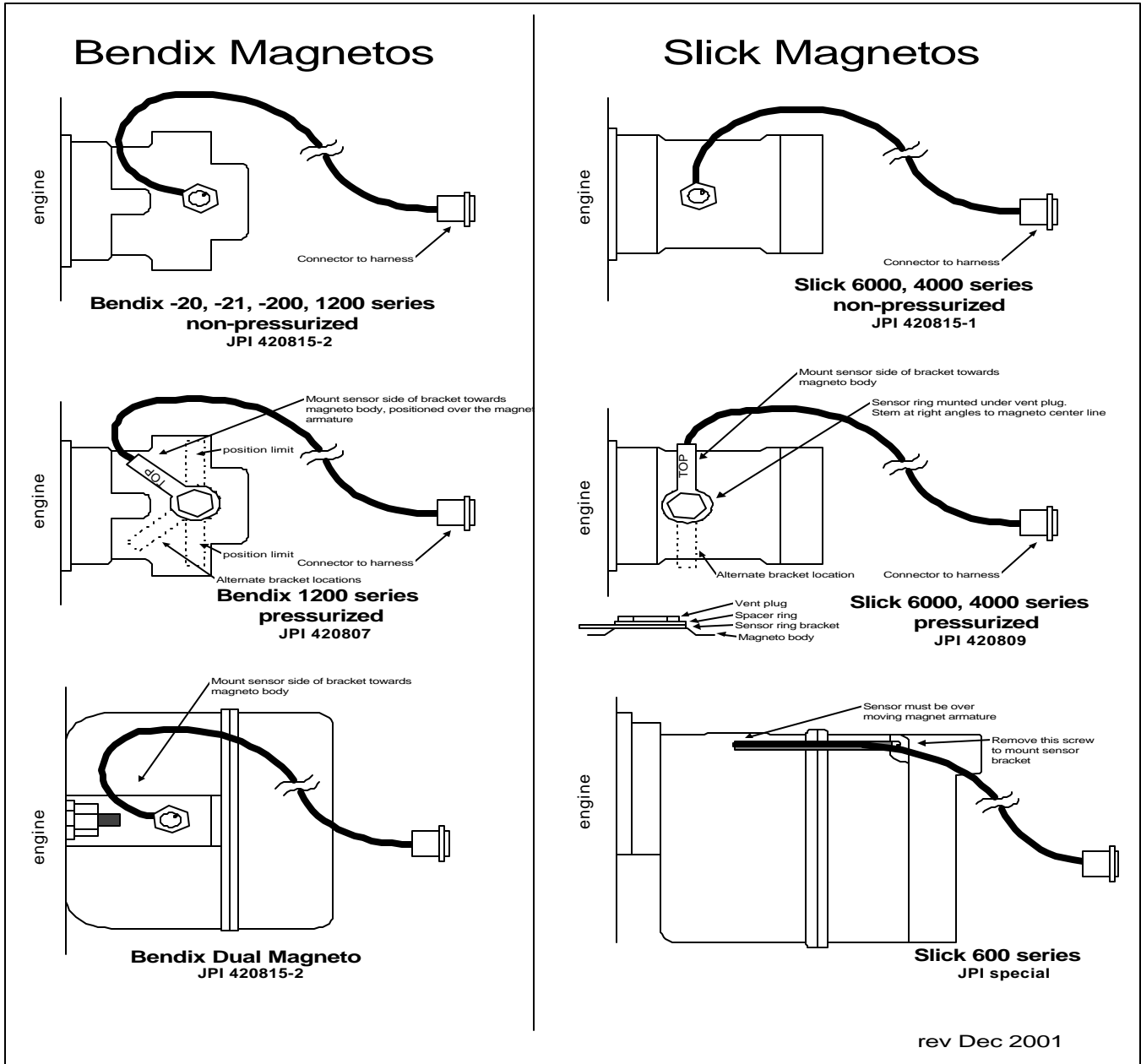

18. ROUTING THE WIRING HARNESS

Route the thermocouple wires from the probes through the firewall using fireproof rubber grommets and flame retarding silicone. Use an existing hole if possible. Following the existing wiring harnesses and connect to the indicator marking each lead with the cylinder number. All wires must be routed **away from high temperature** areas (exhaust stacks, turbochargers, etc.). Secure Probe leads to a convenient location on the engine approximately 8 to 12 inches from the probe, being sure there is sufficient slack to absorb engine torque. It is essential in routing the probe wire that this wire not be allowed to touch metal parts of the air-frame or engine since abrasion will destroy this high temperature wire.

Secure thermocouple wires along the route to the indicator. Secure wire using original clamps, tape or tie wrap if possible.

CAUTION: Be sure the controls under the panel are not obstructed by the wiring.

- The probe wires must not be tied in with **ignition**, alternator or engine cabin heater ignition wires because of potential interference with temperature readings.
- The probe wiring harness is made of Chromel-Alumel alloy wire that **must not be substituted or extended with normal copper wire**. The power and ground wire are normal copper. Leads may be spliced with additional Chromel-Alumel wire using copper butt splices.
- When the installation is complete all wires should be secured using ties and carefully checked for interference, rubbing or chaffing with flight control cables or other moving parts.

19. DESCRIPTION/OPERATING INSTRUCTIONS

The EDM-711 temperature indicator displays temperature digitally and in analog format. The EGT as displayed is based on probes located near the exhaust outlet for each cylinder and the TIT probe, if installed, is adjacent to the turbo charger. Primary CHT, OIL and TIT probes are in the same location as the original aircraft's factory location.

The analog display is an electronic bar graph (vertical columns, one per cylinder) of EGT, OIL, & TIT temperatures presented as a percentage of maximum EGT or TIT (1650 F). Below the vertical columns the specific value for EGT and CHT are displayed digitally, flashing in the specific location, EGT-CHT every few seconds. A scale of CHT from 300 F to 580 F appears on the left side of the window. The dot over the column indicates which cylinder's digital information is presently displayed. The missing bars at the base of the columns indicate CHT from 300 to 500 degrees F with 25 degrees per bar. OIL temperature and TIT are similarly displayed in the right hand column as a percentage of the Limit. The Oil temperature is displayed as the missing bar in the TIT column when the TIT is installed ("T" over column) and as the column when the TIT is not present and the "T" is missing.

Engine Temperature Limit and warning remote lights. Each Primary function has a remote Limit light (red) and caution light (yellow). Any primary alarm causes the digital function (acronym CHT, OIL, and /or TIT) to flash and a remote yellow 'Caution' light or red 'Limit' light to illuminate.

Depressing the LF and STEP button simultaneously brings up the program mode to place the OAT in °F or °C, EGT in 1 or 10 degrees for EGT and K-factor questions. Depressing the LF button will change Oat in °C or °F. Exit by depressing STEP. If either the STEP or LF buttons are not pushed for three minutes the EDM-711 will revert to auto-scanning of the primary functions CHT, OIL, and TIT. Depressing the STEP button will stop the automatic scan and revert to manual scan. Each function is displayed in order, for each push of the STEP button. Holding the STEP button down causes the functions to index in the reverse order.

During constant power cruise, if the LF button is depressed for five seconds the Bargraph will level at mid scale. The leveled bars represent the peaks of each EGT column. Each bar represents 10 °F and now acts as an EGT & TIT trend monitor, quickly showing an increase or decrease in temperature. Depress again to return to normal; nothing else is affected. With the fuel flow option there is a three position toggle switch. The positions are: 1) **EGT**, digital and Bargraph display of temperatures, 2) **FF**, digital display of GPH, REM and USED Fuel. Temperature Bargraph remains. 3) **Both**, cycles through everything installed. The Data memory module will store 25 hrs of flight, recording every 6 seconds.

Options of Fuel Flow, OAT, IAT (induction air temp.), BAT (voltage) are only displayed digitally with acronyms after the number, as "140 IAT" or "14 GPH". A large value (50 +) of "CLD" indicates shock cooling usually associated with rapid descents at low power. Optional functions not installed will not be displayed. RPM is displayed constantly in the top display. Manifold pressure is displayed in the scan sequence.

Primary Alarm Limits:

The Primary orange acronyms are programmed to flash at a specific temperature below the programmed limit before reaching the actual limit, that is Oil 20 F, CHT 40 F and TIT 50 F before the Actual Factory Limit. In this way, only primary functions trigger the alarm lights, but all primary functions provide a cautionary range by flashing the parameter acronyms early. The flashing secondary acronyms direct the pilot's attention to the aircraft's primary instruments for verification. Factory set primary alarm limits for CHT, OIL and TIT (if installed) are the same as the actual aircraft limits and cannot be set by the pilot. The caution and limit lights can only be extinguished by changing power and/or airspeed to reduce the temperatures below the caution or limit trigger points. Tapping the STEP button will stop the display from flashing but will not extinguish the yellow or red lights.

Advisory Alarm Limits:

Exhaust Gas Temperature (EGT), Outside Air Temperature "OAT", Carburetor Air Temperature "CRB", Bus Voltage "BAT", Shock Cooling "CLD", and fuel flow functions "GPH", "REQ", "RES", "MPG", "H.M.", and "USD" appear as orange

gas discharge displays of two or three letter acronyms at the bottom of the instrument for each engine. These limits may be set by the pilot.

Alarm hierarchy;

When a primary parameter limit is reached, the pilot should momentarily depress the STEP button on the EDM instrument to extinguish the particular flashing alarm acronym. If another primary alarm has also reached its limit, that acronym will then begin to flash. For each primary parameter which has reached its limit the alarm light will continue to illuminate until the particular primary temperature has been reduced to below its limit. The pilot should continue to monitor the affected parameters as he would if a conventional analog display had reached a limit. The bar graph functions of CHT, EGT, and TIT remain displayed for easy reference if one of these has reached a limit. Alarm light actuation for a particular parameter limit is based on that parameter which reaches a limit first. If two or more parameters reach their limits at the same time, the order of alarm display is 1 CHT, 2 OIL, 3 TIT. No other parameter limit will flash until the pilot depresses the step button on the instrument. A non-primary alarm is "Canceled" by tapping the STEP button giving a 10 minute cancellation period or by holding the step button in for 5 seconds and seeing the word "OFF". Then, only that particular alarm is canceled. Canceled alarms will not appear again until the power has been removed and reapplied to the EDM-711. The entire display dims with a DIM/BRIGHT switch near the instrument.

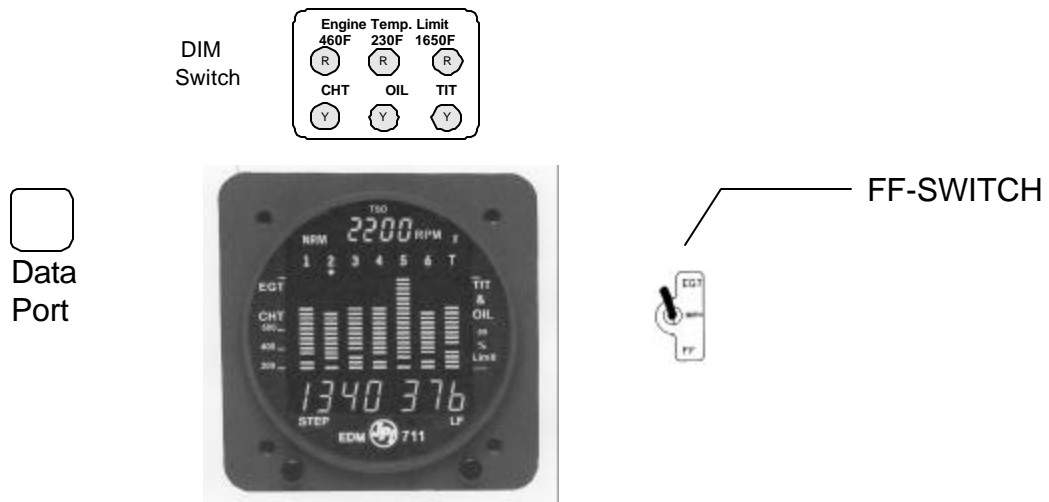

20. ANNUNCIATOR, PRIMARY ENGINE TEMPERATURE LIMITS:

Three types of Engine Limit warning annunciator lights are shipped with the instrument per the primary option requested (JPI P/N 7110-1,-2):. Install the annunciator lights and temperature limit placards in front of and in direct view of the pilot. Displayed below are examples of typical placards with typical numbers, actual temperature limits for those parameters that are primary on a specific aircraft will be used. (see Drawing 711700)

If not required or primary not selected this temperature area is blank.

Installation of annunciator Lights: The Lights individually mount from the rear of the instrument panel. A harness is pre-wired to the lights with a connector that connects to the EDM-711. Plate PN 7110 is sandwiched between the lights and the instrument panel by a mounting nut on the light.

The Caution and Limit alarm lights and their placard MUST be installed in unobstructed clear view of the pilot not more than +/- 8 inches vertically or laterally from the pilots eyes.

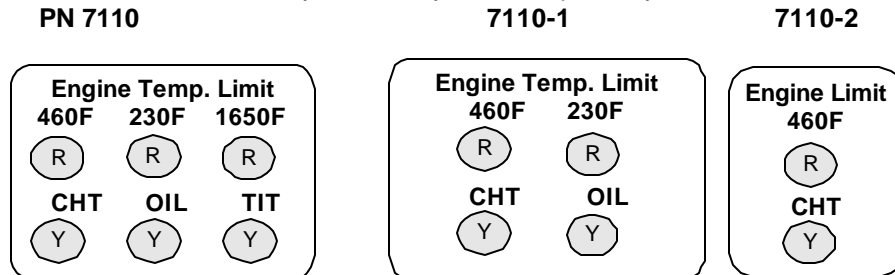

Adjacent to the EDM-711 display (JPI P/N 700905) :
 "Do not rely on fuel flow instrument to determine fuel quantity in tanks"

“Refer to original fuel flow instrumentation for primary information”

21. OPERATION

CAUTION

Comply with manufacturer's Airplane/Rotor craft Flight Manual leaning procedure.
 Do not exceed applicable engine or aircraft limitations.

After establishing desired cruise power depress the LF button to activate the Lean Find Mode. As the mixture is leaned, the column display on the EDM-711 for one cylinder will begin blinking, indicating the exhaust gas temperature for that cylinder has peaked. Continue with the leaning procedure as recommended by the aircraft manufacturer while monitoring the primary engine instruments and the EDM-711 display. Depressing the LF button while the column is flashing will show the peak digital EGT value. Once the leaning procedure has been completed, depress the Step button briefly to exit the Lean Find Mode and enter the Monitor Mode.

EDM-711 SPECIFICATIONS and LIMITATIONS

OUTPUT FUNCTIONS

- EGT (Exhaust Gas Temp.,K ,Max. limit 2500 °F)
- CHT (Cylinder Head Temp., J/K Max. limit 600 °F)
- TIT (Turbine Inlet Temperature, K, Max. limit 2500 °F)
- TIT-2 (Turbine Inlet Temperature, K, Max. limit 2500 °F)
- OIL (Oil temperature, K, Max. limit 600 °F)
- OAT (Outside Air Temp., K, Limit -40 to 300 °F)
- IAT (Induction Air Temp., K, Max. Limit 600°F.)
- CLD (Rate of change of CHT)
- DIF (Maximum EGT differential)
- BAT (Voltage, 0 to 40 volts.)

FACTORY LIMITS

- Per specific Aircraft
- Per specific Aircraft
- Per specific Aircraft
- 1650 °F
- Per specific Aircraft
- 60 °/minute
- 500 °F
- 15.5/12.0 or 31.0/24.0 Hi/Lo

The conditions and test required for TSO approval of this article are minimum performance standards. It is the responsibility of those desiring to install this article either on or within a specific type or class of aircraft to determine that the aircraft installation conditions are within the TSO standards.

Operate and lean the engine in accordance with the manufacturers' recommendations for different power settings. Lycoming recommends running peak EGT only at 75% power or less. Continental recommends running peak EGT at 65% power or less.

22. Component Parts list for Single Engine, EGT and CHT

P.N. EDM-711	-4C	-6C	-7C	-8C	-9C
Temperature Indicator EDM-711	1	1	1	1	1
EGT probe KIT PN 128	4	6	7	8	9
CHT probe KIT PN 126	4	6	6	7	
CHT Gasket probe KIT PN 126			1	1	9
Oil probe with option O KIT 124	1	1	1	1	1
TIT probe with option T KIT 120	1	1	1	1	
OAT probe with option A KIT 122	1	1	1	1	1
IAT probe with option I KIT 130	1	1	1	1	1
MAP P/N 604010	1	1			
RPM one of P/N 420806, 7, 9, 15	1	1			

Component Parts List for EGT (PN 128) ,TIT (PN 120) Probe in polybag

- 1 Thermocouple type K probe
- 1 Stainless Steel Clamp Thimble
- 1 Stainless Steel Exhaust Seal Washer
- 1 Stainless Steel Screw Type Clamp
- 2 Ring Terminals
- 2 Screws and nuts 6-32 X 1/4
- 1 Fiberglass tube 1/2" X 4"

Component Parts list for CHT (PN 126) probe

- 1 Bayonet Probe Thermocouple type K Spring loaded
- 1 Or Gasket thermocouple probe type K
- 2 Ring Terminals
- 2 Screws and Nuts 6-32 X 1/4"
- 1 Fiberglass tube 1/2" X 4"

Component Parts list for OIL (PN 124) probe

- 1 P/N 400505 -C or -L, OIL probe
- 2 Ring Terminals
- 2 Screws and Nuts 6-32 X 1/4"
- 1 Fiberglass tube 1/2" X 4"

Component Parts list for OAT (PN 122) probe

- 1 P/N 400509, OAT probe
- 2 Ring Terminals
- 2 Screws and Nuts 6-32 X1/4"
- 1 Fiberglass tube 1/2" X 4"

Component Parts list for IAT/CARB (PN 121) probe

- 1 P/N 400000 IAT/CARB probe
- 2 Ring Terminals
- 2 Screws and Nuts 6-32 X1/4"
- 1 Fiberglass tube 1/2" X 4"

23. Weight and Balance Data

TSO C43b, Temperature Indicator EDM-711	14.5 oz. / 0.9 lbs
EGT probe MM-111	2.0 oz. each / 0.125 lbs
CHT probe 5050	1.5 oz. each / 0.094 lbs
Wire P.N. WK.-24 Harness 8 ft.	14.0 oz. each / 0.88 lbs
RPM and MAP	1.5 oz each / .094 lbs

24. Pilot Programmable mode:

- "PROGRAM" Stays on for 2 seconds
- "RATE 4" 0 rate = no scan (0 to 9 seconds)
- "OAT F" F or C (OAT Adjust see next section)
- "EGT 1?N" Yes will set the EGT display to One degree resolution. No will set 10 degree resolution.
- "END Y" Quit

PILOT action	EDM-711 display
STEP + LF (both for 2 Seconds)	PROGRAM
1 tap STEP	RATE 4
tap LF to selection	RATE (value 0 to 9)
1 tap STEP	OAT F
tap LF to change	OAT _ (°C or °F)
1 tap STEP	EGT1?N
tap LF to change	EGT1?N or EGT1?Y
1 tap STEP	END Y
tap LF to change	END Y or END N
1 tap STEP	END N - Ends program mode
END Y - returns to sequence again	

25. CHANGING THE PROGRAMMED LIMITS

The programmed limits are changed by pressing the reset button in the back of the instrument when the power is on. The reset button is located in a small hole marked RS.

The STEP button indexes alarms. The LF button changes the limits by holding in to advance and tapping to back up the value.

The following messages and JPI set limits will appear:

"FAC LIM" (Bold headings will display for 2 seconds only)

E

"FAC ? N" (N=NO Y=YES)

Yes.... Reinstalls the generic alarms and will also reset the automatic configuration sequence.

It is necessary to say yes if an option was placed in the wrong connector location. or the instrument is not displaying certain options.

"VER 002" (Software Version)

"ENG F" (All Engine temperatures in °F or °C)
yes-no

If °C is chosen, then ALL alarm limits must be manually reset to °C values.

"BATTERY"

"15.5H BAT" (High Voltage Limit - or 31.0vdc)

"12.0L BAT" (Low Voltage Limit - or 24.0vdc)

"EGT DIF"

"500 DIF" (Difference between highest and lowest EGT)

"CHT HI" (Not changeable if Primary. Set at 460 continental and 475 or 500 Lycoming or per aircraft spec.)

"450H CHT" (Cylinder Head Temperature limit)

"COOL CHT"

"- 60 CLD" (Cool Rate Limit, calculated in degrees per minute for cooling only)

"TIT HI" (Not changeable if Primary set at 1650 or 1750 per aircraft spec.)

"1650 TIT" (Turbine Inlet Temperature Limit)

"OIL TMP" (Not changeable if Primary. Set at 230 Continental and 245 Lycoming or per aircraft spec.)

"230H OIL" (High Oil Temperature Limit)

" 90L OIL" (Low Oil Temperature Limit)

"END Y"

26. TROUBLE SHOOTING

1. **A missing column in the display upon start up** indicates the continuity check diagnostic routine has found an open line or probe with no connection. An error message will indicate which cylinder to look at.
2. **A missing column in the display during flight** indicates a reading that is jumping around or incorrect. The probe is removed from the line up to prevent false alarms.
3. **A negative reading (-)** in front of the number indicates reverse polarity on the red/yellow wire to probe.
4. **Using an Ohm meter** or continuity checker measure across the probe output leads. A good probe should be around 2- ohms and at the connector to the probe around 20 ohms.
5. **Having problems with one cylinder reading ?** Swap the suspected probe with a probe from a good cylinder. If the problem goes to the good cylinder the probe should be replaced. If the problem remains the same, it is in the Thermocouple hook-up wiring from the probe to the instrument or it can be in the ring terminals crimped to the wire. Remember to double back on the wire going into the ring terminal.
6. **Display jumps when transmitting** on the radio. Review fig-6, a kit is available to stop transmission noise it connects on pin 11 connector P-1, (mike key button).
7. **EGT, large span.** Normally aspirated (carburetor) engines at normal cruise display a "DIFF" of 125 to 175 °F spread between cyls. Injected engines at normal cruise display a "DIFF" 50 to 90 °F spread between cylinders. All cylinders are measured by a common circuitry. It is almost impossible **not to have** identical calibration on all channels.
8. If the temperature is changing more than 500 F in one second it should not be trusted and a loose wire crimp or probe should be suspected.
9. **All EGT or CHT readings seem to High or Low or Unsteady.** Use a DVM (digital voltmeter) to measure the difference between 711 SCANNER ground and the engine block ground. If the difference is greater than 0.5 volts with the alternator charging. Then remove the EDM-711 ground (Black wire) from the instrument panel and connect it directly to the ENGINE BLOCK for GROUND.
10. **OAT readings off by 25 degrees,** but oil and CHT readings OK, look for *copper wire spliced* in line to OAT probe. OAT reading can be fine tuned +/- 5 degrees, see reset procedure. Engine heat could also be the cause.
11. **Gem conversion, CHT's read high** (100 degrees) EDM-711 not "J" calibration, for Gem installation return to factory.
12. **Copper Wire can not be substituted for thermocouple wire at any point.**

START UP ERROR LIST and PROBE LOCATION

Display indicates "OPEN PRB" then the following message:

EGT 1	CHT 1	OIL
EGT 2	CHT 2	
EGT 3	CHT 3	IND.
EGT 4	CHT 4	OAT
EGT 5	CHT 5	TIT
EGT 6	CHT 6	
EGT 7	CHT 7	
EGT 8	CHT 8	
EGT 9	CHT 9	

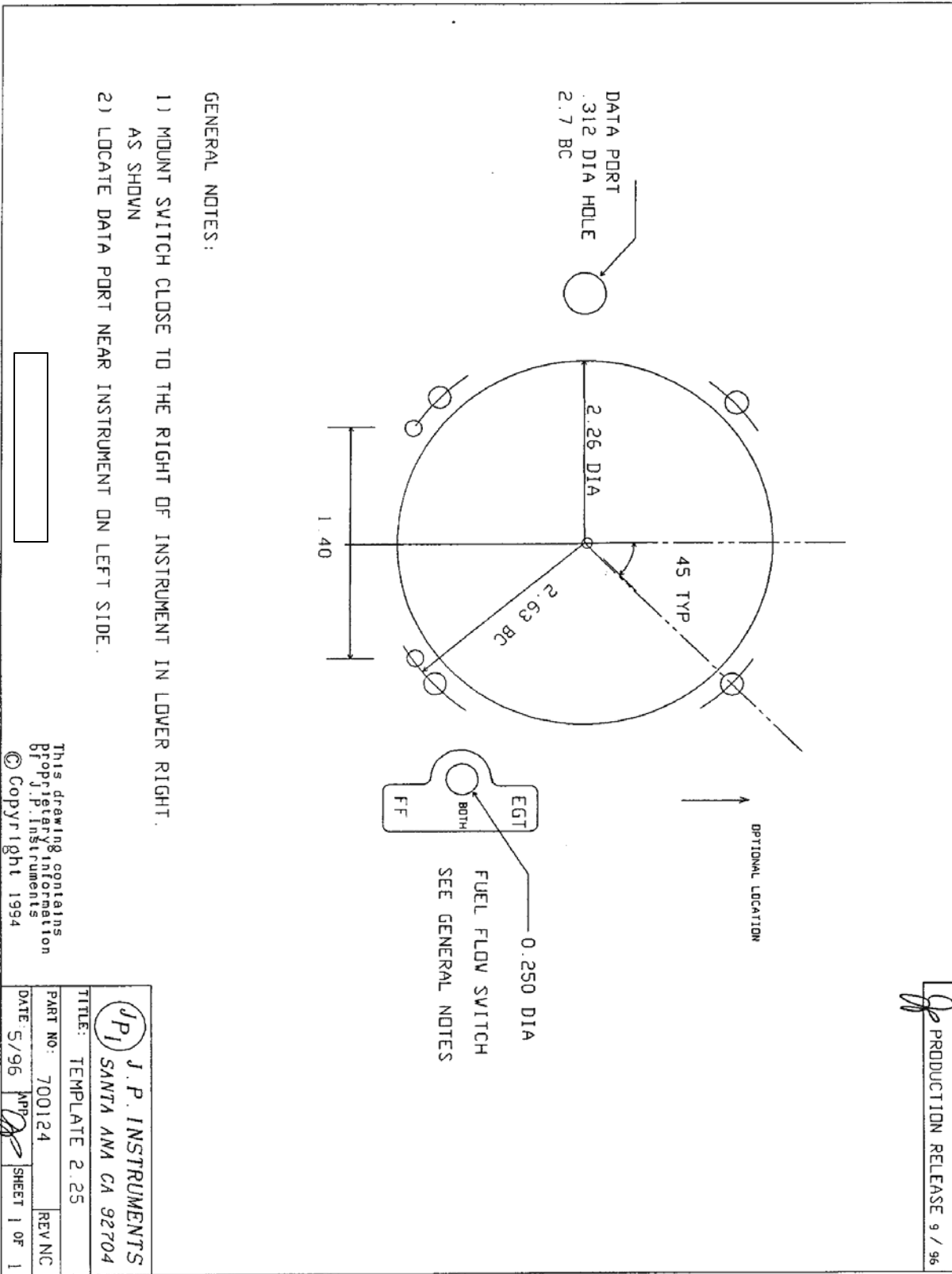
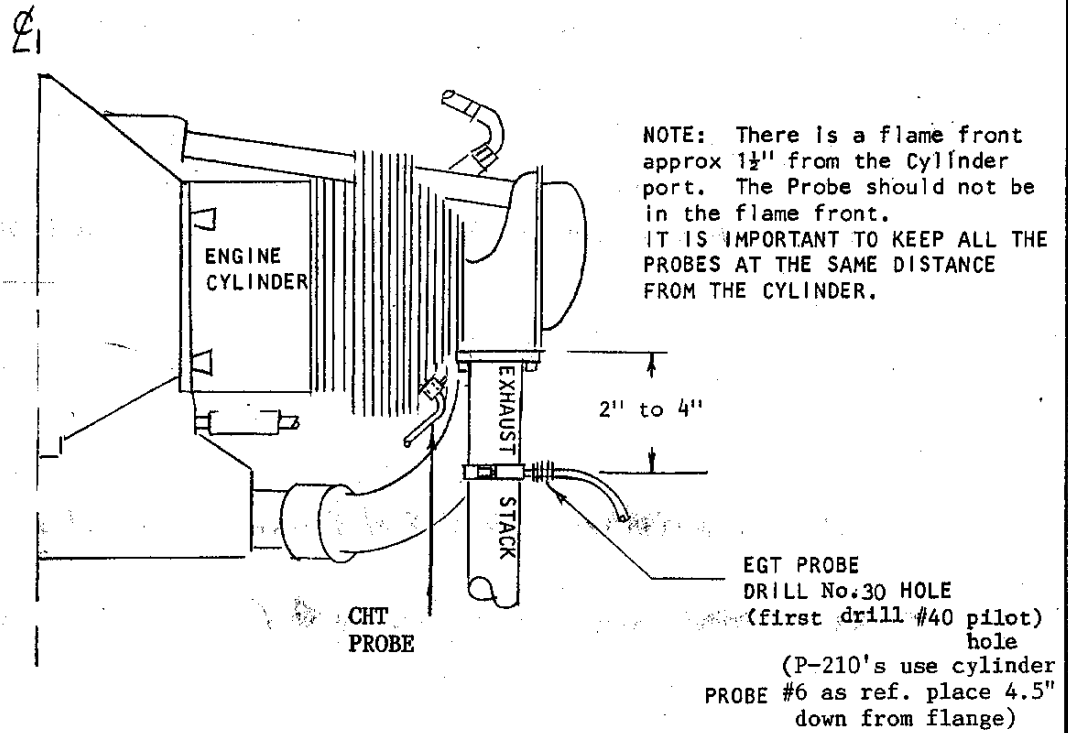

FIG-1



EGT - CHT PROBE LOCATION

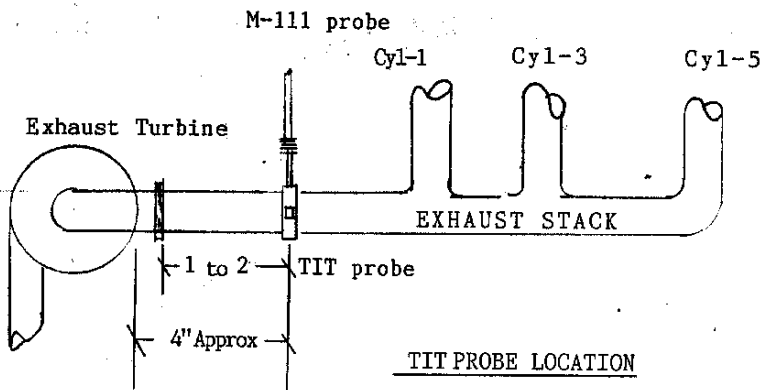

FIG-2

PROBE INSTALLATION INSTRUCTIONS

The K/MM-111 Probe will fit an 1/8 (.125) to 1/4 inch dia. hole in the exhaust stack that is approximately 3 to 4 inches from the cylinder exhaust port. Installation is extremely simple and requires no special tools or welding.

Assembly is accomplished by inserting the stainless steel thimble thru the hole in the clamp, inserting the probe in the thimble and applying the sealing washer between the thimble and the exhaust stack in such a position that the radius of the washer follows the curvature of the stack.

Insert the probe in the exhaust stack so that the tip of the probe is in the approximate center of the exhaust stack. Try not to go over center. Make certain that the slot in the thimble is positioned **LONGITUDINALLY** with the length of the exhaust stack or the probe will not lock firmly. Tighten the clamp firmly, which will lock the probe thimble assembly and probe in position.

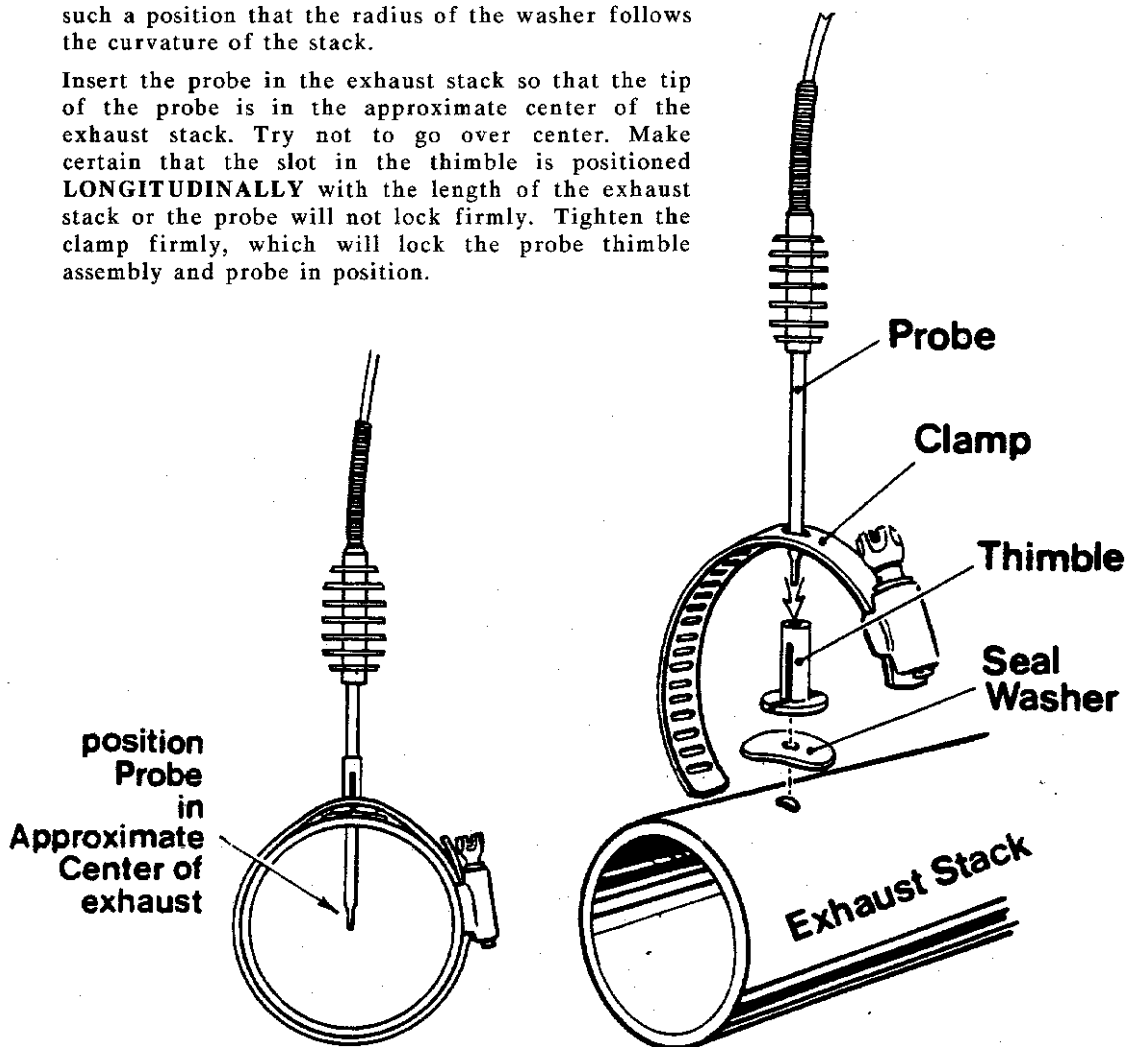

FIG-3

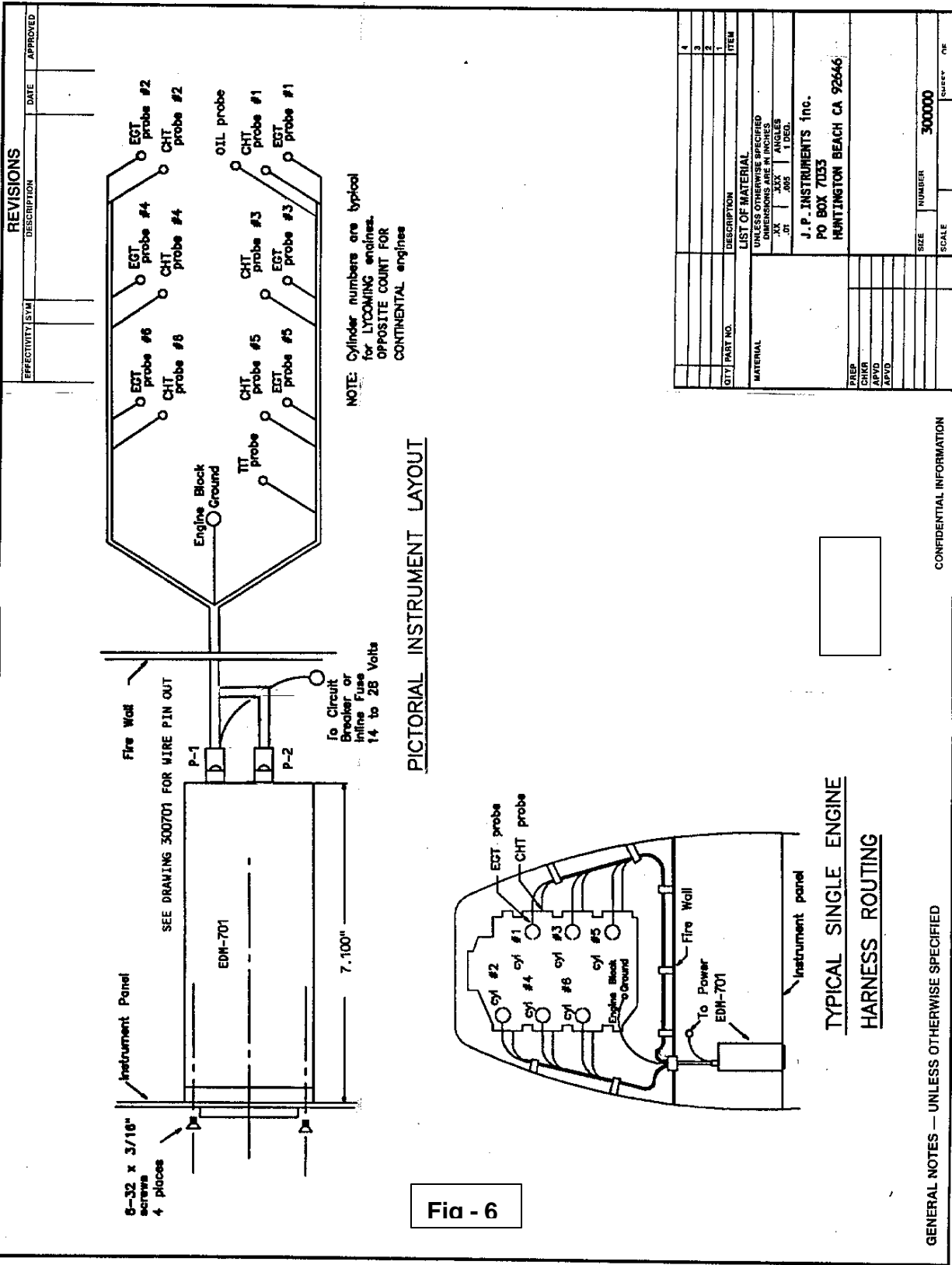

Fig - 6

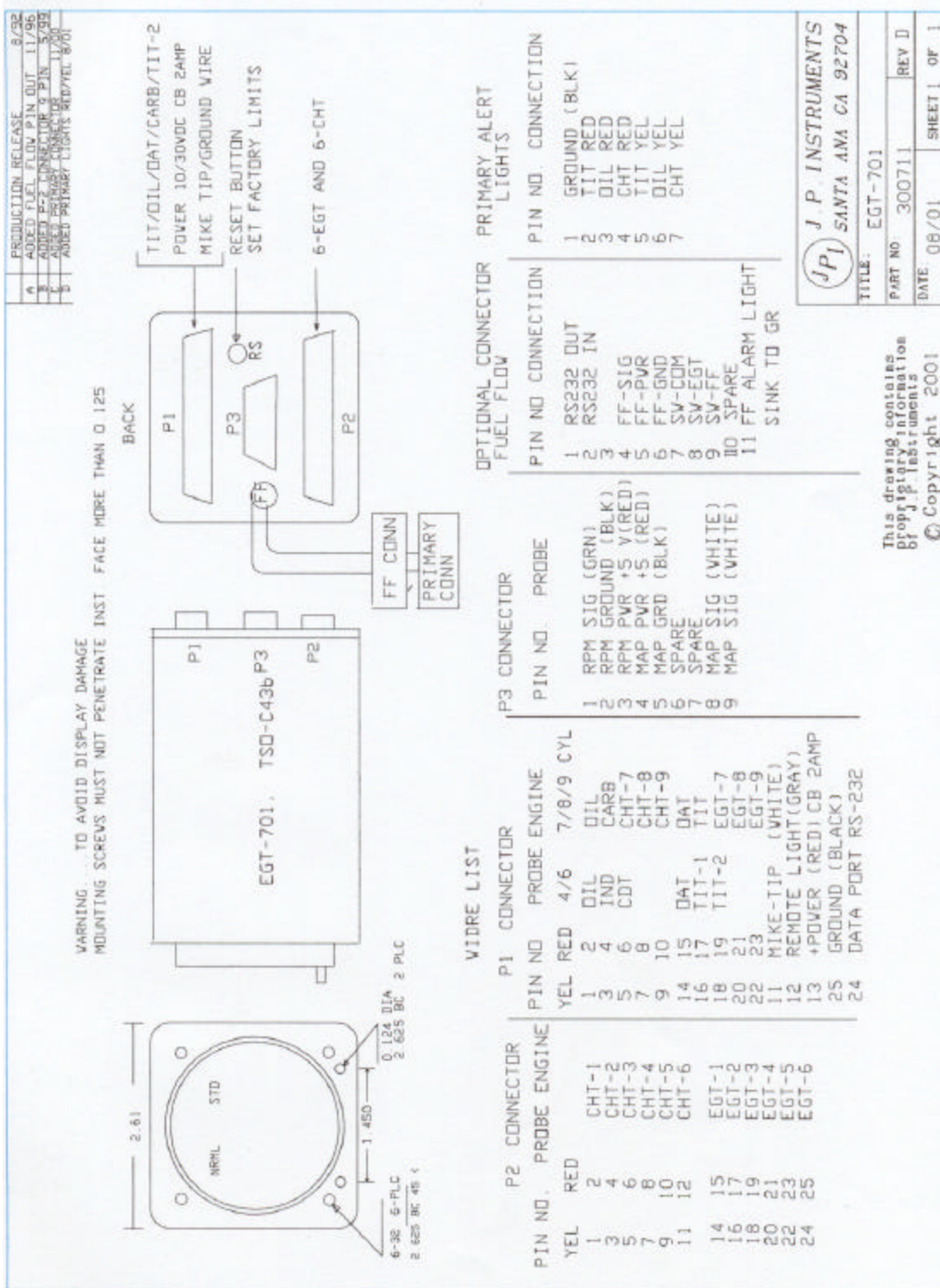

Fig - 7

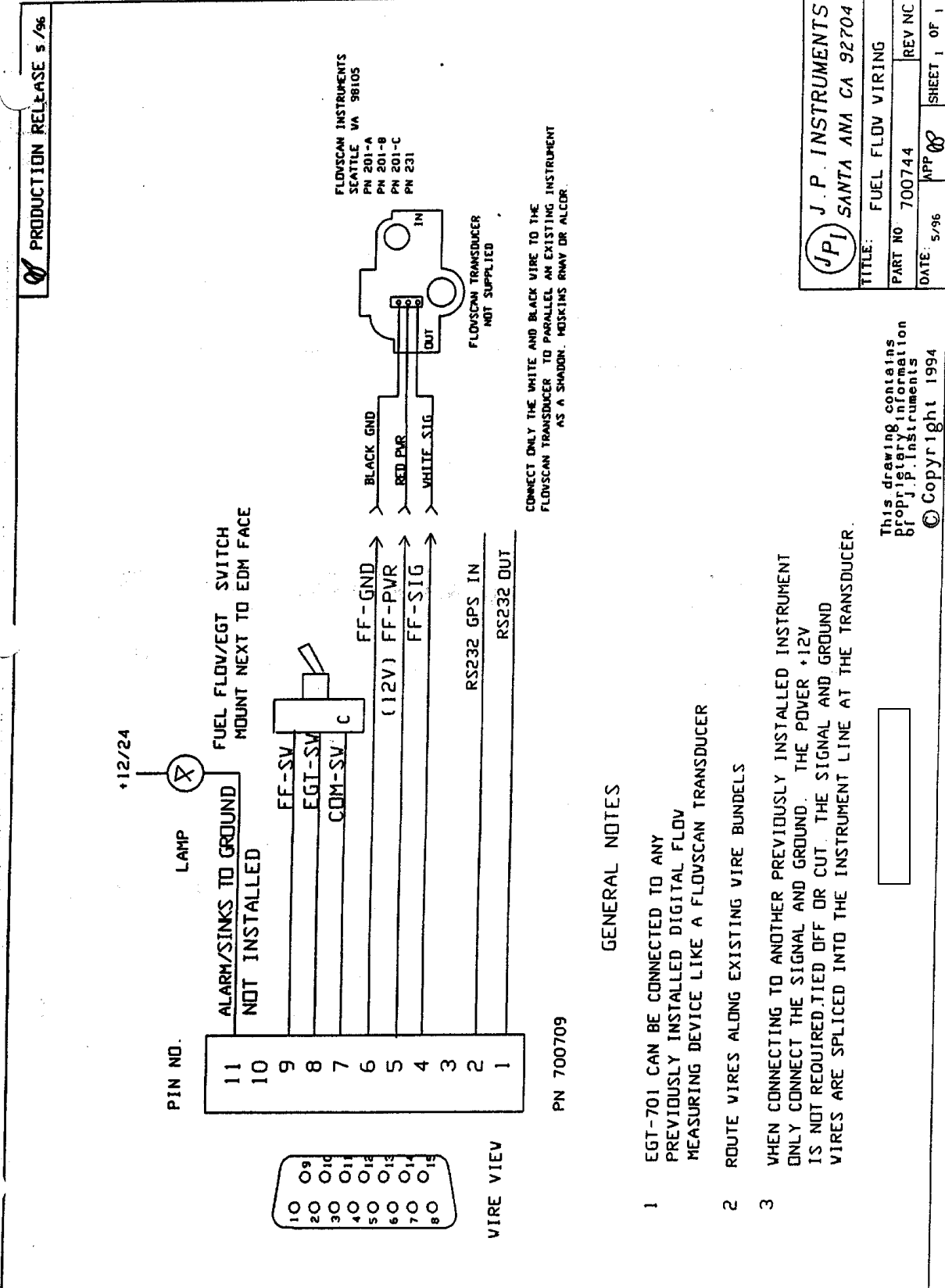

FIG - 8

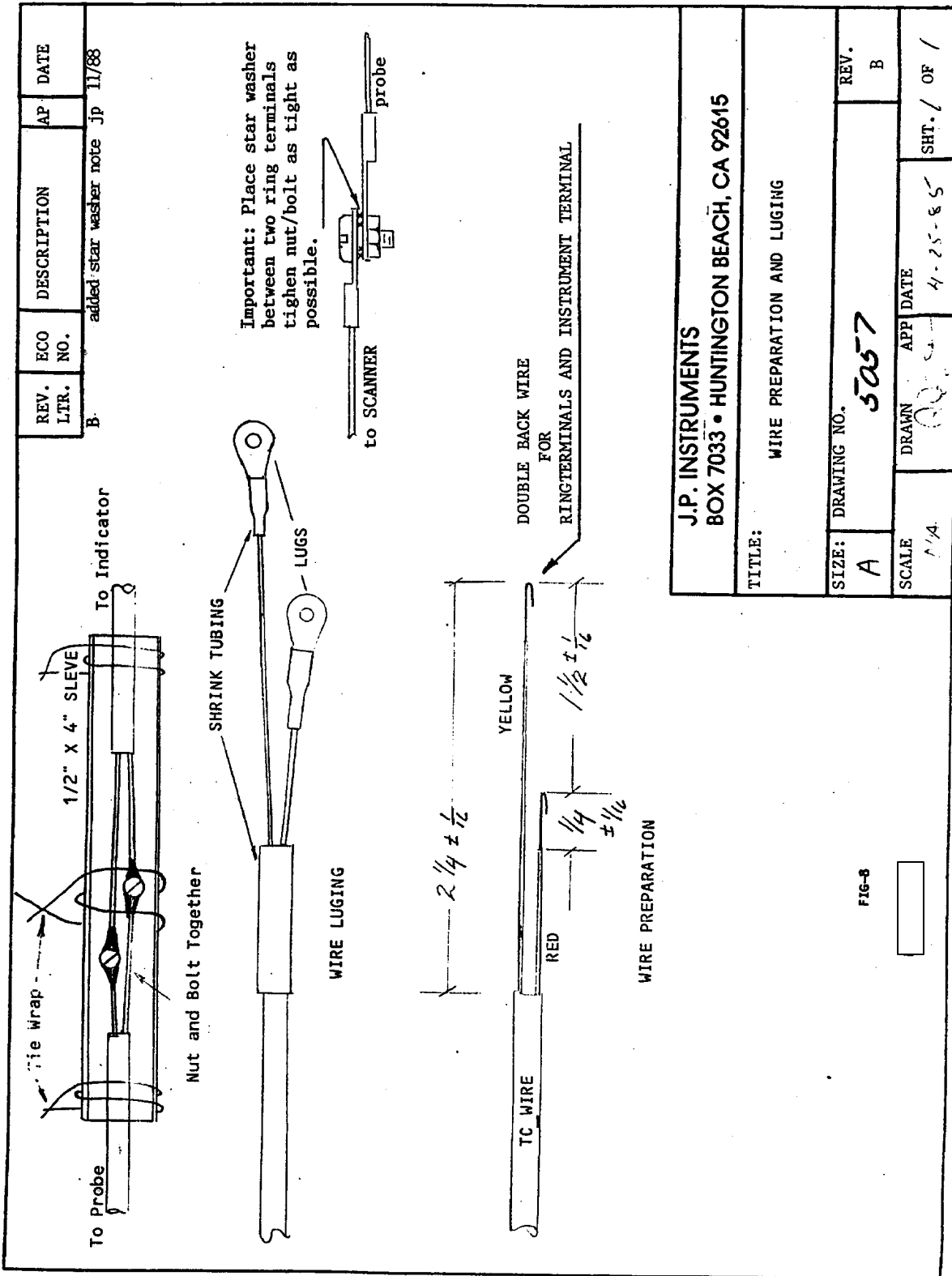
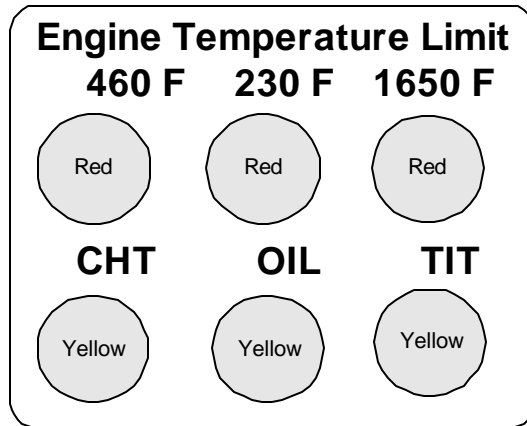

FIG-9

Nomenclature is silk-screened for specific aircraft



Mounting Plate
 PN 7110

Front View with Six Lamps showing

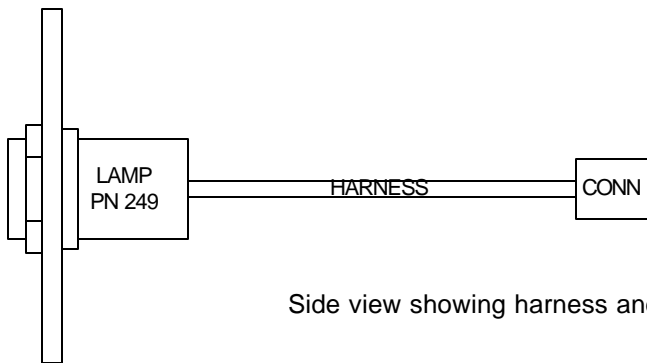

Side view showing harness and connector

General Notes:
 Depending on the number of primary functions, drill a 0.375 hole thru the instrument panel for each lamp. Lamps are located on 0.75 centers. Lamps mount from the rear of the panel and have adjusting nuts on each side.

J.P. INSTRUMENTS			
PO Box 7033 Huntington Beach CA 92646			
Title : Remote Light Ass'y.			
Drawing No. 711700			
Date 11/20/00	Drawn JP	Approved 	Rev NC

PRODUCTION RELEASE 12/96

**DO NOT RELY ON FUEL FLOW INSTRUMENTS
TO DETERMINE FUEL LEVELS IN TANKS**

PN 700905-1

**REFER TO ORIGINAL FUEL FLOW
INSTRUMENTATION FOR PRIMARY INFORMATION**

PN 700905-2

General Notes:
Material, Aluminum foil or Polycarbonate
Font size 6 point
Size 1.5" x 0.25"

Install the placards near the Fuel Flow / EGT switch

J.P.INSTRUMENTS

PO Box 7033
Huntington Beach CA 92646

Title : Placards

Drawing No. 700905

Date
11/22/00

Drawn
JP

Approved



Rev A

Instructions for Continued Airworthiness (ICA)

There are no field adjustments and or calibration requirements for the EDM-700 series instrument after initial installation. ICA is not required. Maintenance of nonfunctioning or malfunctioning components is limited to removal and replacement of JPI factory supplied new or repaired components as described in the troubleshooting section of the installation instructions