

**Table of Contents**

	Page
1. General	2
2. External annunciator light	2
3. Install the instrument in the panel	2
4. Route the Fuel Flow Transducer Wires	2
5. Installing the Fuel Flow Transducer per report 503	2
6. List of major components:	2
7. TSO Conditions	2
8. Specifications and Limitations	3
Drawing 450124 mounting template	5
Drawing 450507 wiring diagram	6
Initial Check Out	7
System Checkout	7
Operating Instructions	8
Instructions for Continued Airworthiness	9
Appendix –A Report No. 503, transducer installation	

J.P.INSTRUMENTS  
PO BOX 7033  
HUNTINGTON BEACH CA 92704

### Installation Instructions

1. **General:** A complete thorough familiarization and understanding of the system and this manual is necessary before commencing the installation. All work must conform with A.C. 43.13.1A ch. 11 sec. 2, 3, 7. The accuracy of this instrument depends entirely upon the accuracy of the data entered. A periodical checking of the actual fuel onboard will eliminate the accumulation of errors due to evaporation leaks, etc.
2. **Route the (Optional) External Warning Control Line:** The wire from pin 4 on the J-1 (D-SUB 9) Connector can be connected to an external warning light or buzzer. This wire grounds when the display flashes a warning. The current in this line must be limited to 0.25 amp maximum. Exceeding this limit will damage the unit. If this feature is not used leave this line open. Tie wrap this wire so it does not obstruct the freedom of travel- controls. The FS-450 can be connected in parallel to any existing digital fuel flow system. In this case pin 3 red is not connected. See drawing 450507.
3. **Install the Instrument in the Panel:** Locate a 2.25 diameter hole in the instrument panel, where you would like to mount the indicator per drawing 450124. The FS-450 , mounts in a standard 2.25" instrument hole. The instrument **configures itself automatically**, for 14/28 volt aircraft. The instrument is 1.5" deep less connectors and is 2.6 square behind the panel.
4. **Route the Fuel Flow Transducer Wires:** Route the fuel flow wires from the probes through the firewall using fireproof rubber grommets and flame retarding silicone. Use an existing hole if possible. Following the existing wiring harness. All wires must be routed **away from high temperature** areas (exhaust stacks, turbochargers, etc.). Secure Probe leads to a convenient location on the engine, being sure there is sufficient slack to absorb engine torque. It is essential in routing the fuel flow transducer wires not be allowed to touch metal parts of the air-frame or engine since abrasion will destroy this wire. Connect wires in accordance with Dwg 450507.
5. **Installing the Fuel Flow Transducer:** Mount the Fuel Flow Transducer using the appropriate drawing in Report 503.

Aircraft Configuration	Drawing/Report 503	Location
1. <b>PN 450000-G</b> All gravity Flow installations <b>without</b> fuel pump. Must use transducer PN 700900-2	700923	Between Fuel tank and Carburetor.
2. <b>PN 450000-P</b> All Fuel injected engines <b>with</b> vapor return lines to fuel tank , all Continental and certain Lycoming engines.	700922	Between throttle body and fuel flow divider.
3. <b>PN 450000-P,-H</b> All pump fed carbureted and Fuel injected engines <b>without</b> vapor return lines. PN 450000-P range up to 60 GPH and PN 450000-H range up to 120 GPH	700921	Between engine driven pump and servo/throttle body or carburetor
4. <b>PN 450000-D</b> Pressure Carbureted engines with vapor return lines. Requires Dual transducers	700924 450508	One transducer in Carb inlet line and one transducer in out let line
5. <b>PN 450000-M-( )</b> If "M" is after the PN it signifies that the display has Matrix displays .		

6. **List of major components:**

PN 450000-( )	-P	-G	-D	-H
Indicator PN 450000	1	1	1	1
Harness PN 450507	1	1	1	1
Transducer PN 700900-1	1		2	
Transducer PN 700900-2		1		
Transducer High Flow PN FT4-8AEXS-LEA-2029				1

## **7. TSO Conditions**

"The conditions and test required for TSO approval of this article are minimum performance standards. It is the responsibility of those desiring to install this article either on or within a specific type or class of aircraft to determine that the aircraft installation conditions are within the TSO standards. The article may be installed only if installation of the article is approved by the Administrator."

## **8... Specifications and Limitations**

### **Model:**

FS-450 , PN 450000 (series)

### **Case Dimensions:**

2.5" x 2.5" x 1.5" depth, 2 1/4" Bezel.

### **Weight:**

Unit Only: 4 oz

Flow Transducer: 3 oz

### **Environmental:**

-40 TO 85C

### **Power Requirements:**

10 to 35 Volts, 0.2 Amp.

### **Low Fuel Warning Display**

The display message will blink anytime the programmed Low Fuel Reminder, Low Fuel Warning or the Time to Empty Limit are violated.

### **External Warning Control Line:**

Grounds when any Warning display is on or blinking. Current should be limited to 2/10 amp.

### **Accuracy:**

Flow: 2% or better in accordance with TSO C44a.

### **Resolution**

Fuel Flow: 0.1 Gal. or 1 Lb. or .1 Ltr.

Fuel Remaining: 0.1 Gal. or 1 Lb. or .1 Ltr.

Fuel Used: 0.1 Gal. or 1 Lb. or .1 Ltr.

Time to Empty: 10 minute

### **Max Displayed Range (Unit Only):**

Fuel Flow: 199.9 Gals. or 162.0 or Gal/Hr or 1199 Lbs/Hr or 749 Ltr/Hr.

Fuel Remaining: 999 Gals. or 811 or Gals. or 1999 Lbs. or 1999 Ltrs.

Fuel Used: 999 Gals. or 811 or Gals. or 1999 Lbs. or 1999 Ltrs.

Time to Empty: 19 hours 59 minutes

## 8... Specifications and Limitations cont.

<b>Fuel Flow Transducer, Standard (FXT-201)</b> <b>Instrument P/N 450000-P, -D</b> <b>Transducer P/N, 700900-1</b>	<b>Fuel Flow Transducer, Gravity Only (FXT-231):</b> <b>Instrument P/N 450000-G</b> <b>Transducer P/N 700900-2</b>
Range: 0.6 to 60 GPH	Range: 3 to 90 GPH
Linearity: %1 (8 to 60 GPH)	Linearity: %1 (8 to 60 GPH)
K Factor: Approx. 29,000	K Factor: Approx. 19500
Pressure Drop: 1.2 PSI at 30 GPH 4.8 PSI at 60 GPH	Pressure Drop: .31 PSI at 30 GPH 2.8 PSI at 90 GPH
Working Press: 200 PSI	Working Press: 200 PSI
Min. Burst Press: 2000 PSI	Min. Burst Press: 2000 PSI
Non Operating Temp. Range: -65 °C to 100 °C	Non Operating Temp. Range: -65 °C to 100 °C
Operating Temp. Range -55 °C to 70 °C	Operating Temp. Range -55 °C to 70 °C
Fuel Ports: 1/4" Female NPT	Fuel Ports: 1/4" Female NPT

<b>Hi Flow Transducer</b> <b>Instrument P/N 450000-H .</b> <b>Transducer P/N (FT 4-8AEXS-LEA-2029)</b>
Range: 3 to 120 GPH
Linearity: %1 (9 to 120 GPH)
K Factor: Approx. 48,000
Pressure Drop: 0.23 PSI at 30 GPH 0.8 PSI at 60 GPH
Working Press: 1500 PSI
Min. Burst Press: 2000 PSI
Operating Temp. Range -55 °C to 70 °C
Non Operating Temp. Range: -65 °C to 100 °C
Fuel Ports: AN816-8-8

## 9... Pilot Programmable Modes:

<b>RS232/422 Input Ports (FS-450 ),with Fuel Flow option Only!:</b>	
Single Line Receive Method:	RS-232C, RS423, or 5 Volt Serial.
Dual Line Receive Method:	RS-422 or RS-485.
Protocol:	1 Start bit, 8 Data bits, 1 Stop bit.
Baud Rate:	L 1 = 9600, L 2 = 1200
Format:	Moving Map Output: L 1 = King KIN-88, L 2 = Northstar

<b>RS232 Output Port</b>	
Transmit Method:	RS-232 Single Line.
Protocol:	1 Start bit, 8 Data bits, 1 Stop bit.
Baud Rate:	Automatic: 9600,4800,1200
Transmit Format:	Automatic: Aviation Date, Northstar Binary, NMEA-183

PRODUCTION RELEASE 3/00

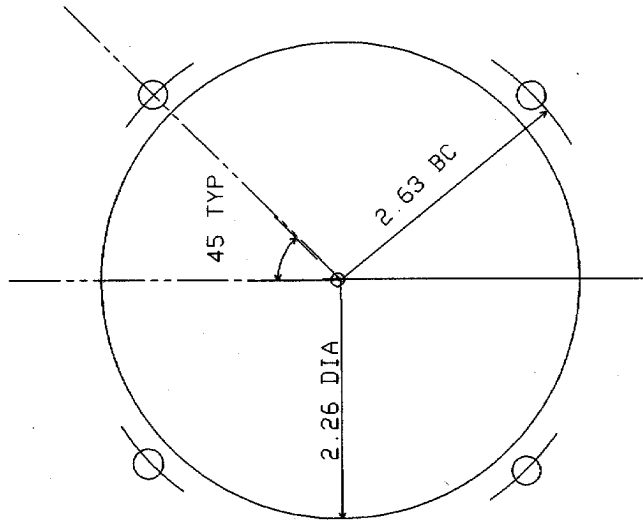

GENERAL NOTES:

 J. P. INSTRUMENTS SANTA ANA CA 92704	TITLE: TEMPLATE 2.25
	PART NO: 450124 REV NC
DATE: 3 / 00 APP	SHEET 1 OF 1

This drawing contains  
Proprietary information  
of J.P. Instruments  
© Copyright 2000

FIG - 12

# J.P.Instruments Fuel Flow Installation Manual

FS-450

FAA Approved

Report # 400

Page 6 of 9

Rev A : Date 08/09/2002

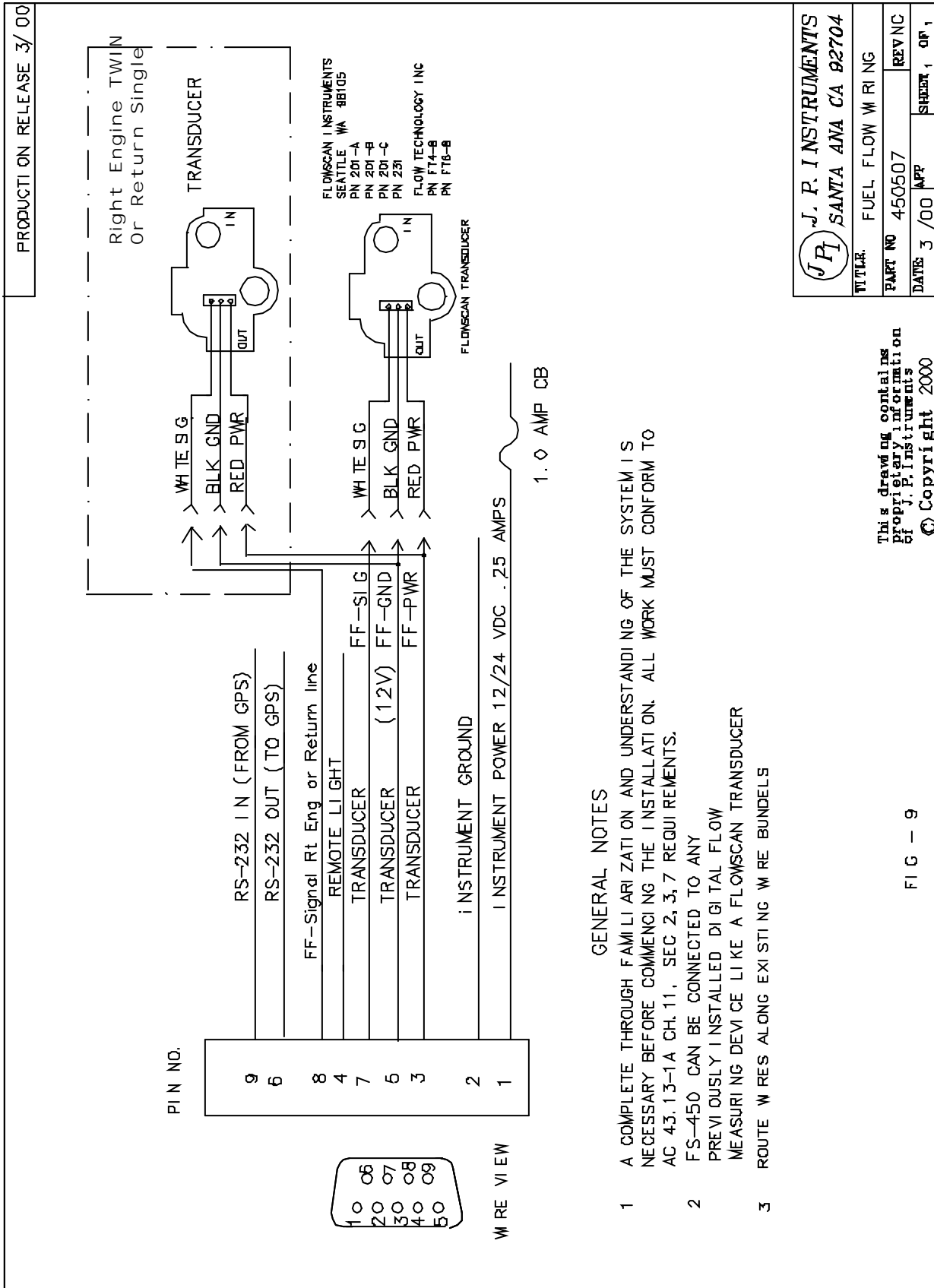

## Initial Check Out

1. **System Warranty:** The aircraft owner must read the Warranty before starting the installation. There is information in the Warranty that may alter your decision to install this instrument. If you do **not accept the terms of the Warranty, JPI offers a 30 day money back guarantee.**
2. **Transducer Warranty:** All transducers suspected of malfunctioning must be sent back to JPI to be flow tested at the manufactures factory at a cost of \$70. JPI sends the transducer back to the manufacturer for flow checking, who in tern charges JPI. If the transducer is found defective a new transducer will be issued.
3. **If you are not an FAA Certified Aircraft Mechanic familiar with the issues of installing aircraft fuel flow, Do Not attempt to install this instrument.** The installer should use current aircraft standards and practices to install this instrument (refer to AC 43.13).
4. Read the entire Installation Instructions and resolve any issues you may have before starting the installation.
5. **THIS INSTALLATION WILL REQUIRE SOME PARTS UNIQUE TO YOUR AIRCRAFT THAT ARE NOT SUPPLIED IN THE KIT (including, but not limited to hoses and fittings).** Acquire all the parts necessary to install this instrument before starting the installation. **Do not use aluminum fittings** with the FXT-201 or FXT-231 transducer.
6. Check that the instrument make and model are correct before starting the installation (check the markings on the side of the instrument). A gravity feed system requires an FXT-231 flow transducer (marked "231" on top). A carbureted engine with a fuel return line requires two transducers at additional cost.
7. If this instrument is to replace an existing unit in the aircraft, it is the installer's responsibility to move or replace any existing instruments or components in accordance with FAA approved methods and procedures. The following Installation Instructions do not cover moving or the removal of any existing instruments or components.
8. Before connecting any hoses to the transducer, thoroughly clean them and insure they are free of any loose material. **Never pass high pressure air through or blow through the transducer, damage will occur.**
9. Remove the transducer cap plugs when ready to install hoses. **Do not use aluminum fittings** with the fuel flow transducer or Gauling may occur.
10. The inlet and outlet ports of the transducer have ¼ NPT threads. When assembling fittings into the inlet and outlet Do Not Exceed a torque of 15 ft. lbs. Or screw the fittings in more than 2 full turns past hand tight.
11. A screen or filter should be installed upstream of the transducer. As turbulence upstream of the transducer affects it's performance, there should be a reasonable length of straight line between the transducer inlet.
12. Install the transducer with the wires leads UP to vent bubbles and insure that the rotor is totally immersed in fluid.
13. Note the direction of fuel flow marked on the transducer. Fuel must flow in this direction.
14. Note and record the K-factor engraved in the side of the transducer and also on the white tag attached to the transducer. Most transducers have a K- factor of 29.90.

### **System Checkout:** Check instrument operation as follows:

- Turn the aircraft master switch on (engine off). Tap the step switch until 0 GPH is displayed. Turn the boost pump on for a few seconds. The display should indicate 3 to 8 GPH.. A problem at this step could be caused by poor connections on the red or black power and ground leads.

### FAA Approved

- A reading of “ --- ” dashes indicate no fuel flow transducer signals. A problem at this step could be caused by a poor connection or crossed flow transducer wires.
- With the engine running, check the "FLOW" Display to read properly.
- **After running the engine, check the fuel hoses, transducers and fittings for leaks.**

### Operation Instructions

The FS-450 Fuel Scan uses a small turbine transducer that measures the fuel flowing into the engine. Higher fuel flow causes the transducer turbine to rotate faster which generates a faster pulse rate. Prior to engine start you inform the FS-450 Fuel Scan of the known quantity of fuel aboard, and it will keep track of all fuel used. There are two standard operating modes of the FS-450: Automatic Scanning, and Manual Scanning. The FS-450 has programmable alarms. When the remaining amount of fuel falls below the alarm limit the bottom display will show the amount of fuel REMaining and the specific cue light will flash. When the remaining time falls below the alarm limit the bottom display will show the MINutes of fuel remaining and the specific cue light will flash. When an alarm is displayed, tapping the STEP button will temporarily disable the alarm indication for the next ten minutes. When an alarm is displayed, holding the STEP button until the word **OFF** appears will disable that alarm indication for the remainder of the flight. After initial self-test, you will be asked to inform the FS-450 of start up fuel. The FS-450 will display **FUEL GAL** (or **Lt r** liters or **LbS** pounds) for one second, and then flash **FILL P n** until any button is pressed. The display will pause at each parameter for a few seconds in the Automatic scanning mode. In the Manual scanning mode, tap the STEP button to advance to next parameter. Holding the STEP button will display the previous parameters in the sequence (rapidly backwards).

**Procedure—Changing the Set Up by entering the program mode.**

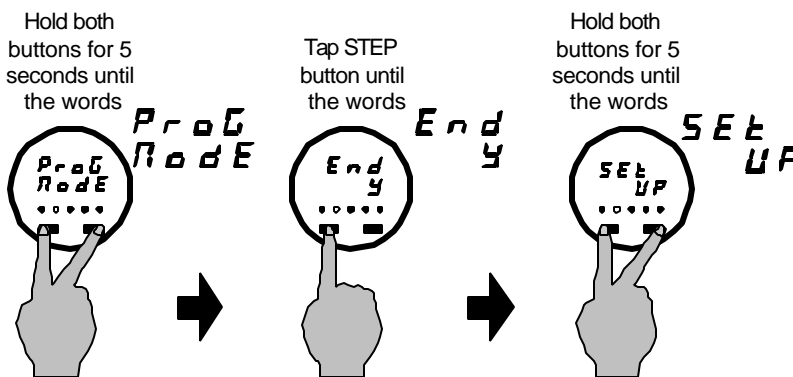

Tap STEP to next item	AUTO sequences through these values	Description
<b>FUEL GAL</b>	<b>GAL</b> ⇒ <b>Lt r</b> ⇒ <b>LbS</b> ⇒	Selects fuel units
<b>MAIn = 50</b>	Hold or tap AUTO to select main capacity	Main tank capacity, in units selected
<b>AUX? n</b>	n ⇔ <b>Y</b>	Y—Yes—aircraft has auxiliary tanks (next step)
<b>AUX = 0</b>	Hold or tap AUTO to select AUX capacity	Auxiliary tank capacity (skipped if AUX? is no)
<b>Min = 45</b>	Hold or tap AUTO to select low time limit	Alarm limit in minutes for low time in tanks
<b>REN = 10</b>	Hold or tap AUTO to select low quantity limit	Alarm limit for low fuel quantity in tanks, in units selected
<b>carb? n</b>	n ⇔ <b>Y</b>	Y—Yes—carbureted engine

E n d Y	n ↔ Y	Y—Yes to exit; N—No to review list again
------------	-------	--

- Digital display for numeric readouts and messages: top display is fuel flow and the lower display for all other parameters.
- Indicator lights to show what information is being displayed on the digital display

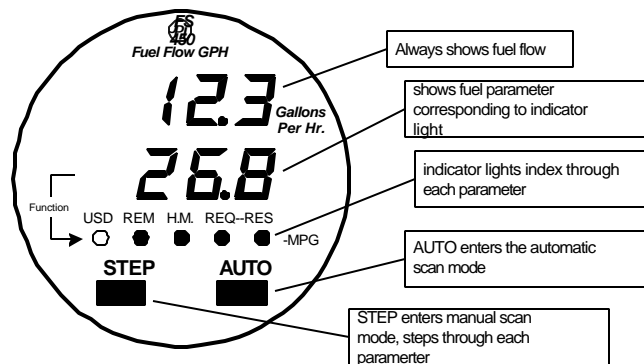
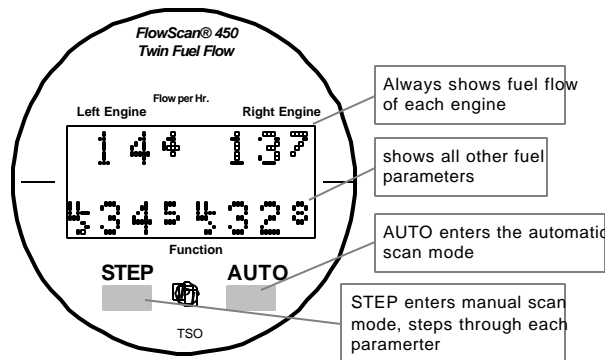

Parameter Description	Example	Comments
<b>USD</b> —Total Fuel Used	38.2	Since last refueling or trip total.
<b>REM</b> —Fuel Remaining	37.2	In gallons, liters or pounds
<b>H.M.</b> —Time to Empty	02.45	<b>Hours. Minutes</b> Remaining at current fuel burn
<b>REQ</b> —Fuel required to next GPS WPT or Destination	25.8	Present with GPS interface Valid signal and way point
<b>RES</b> —Fuel Reserve at next GPS WPT or Destination	11.3	Present with GPS interface Valid signal and way point

## Instructions for Continued Airworthiness (ICA)

There are no field adjustments and or calibration requirements for the FS-450 series instrument after initial installation. ICA is not required. Maintenance of nonfunctioning or malfunctioning components is limited to removal and replacement of JPI factory supplied new or repaired components as described in the troubleshooting section of the installation instructions